

Polaris / Sportsman 570 Touring

No.: 2444.7438.1
Brend: Polaris
Model: Sportsman 570 Touring
Year: 2016 -
Material: Al - 4 mm



Content

1. Plate 1.....	1 pc	16. Bracket.....	2 pc
2. Plate 2.....	1 pc	17. Bracket.....	1 pc
3. Plate 3.....	1 pc	18. Bolt M6x20.....	4 pc
4. Plate 4.....	1 pc	19. Screw M6x20.....	2 pc
5. Plate 5.....	1 pc	20. Screw M6x50.....	2 pc
6. Plate 6.....	1 pc	21. Bolt M8x25.....	37 pc
7. Front arm guards.....	2 pc	22. Bolt M8x50.....	2 pc
8. Rear arm guards.....	2 pc	23. Round-head bolt.....	6 pc
9. Insert nut M8.....	5 pc	24. Nut M6.....	6 pc
10. Bracket.....	3 pc	25. Nut M8.....	2 pc
11. Insert nut M6.....	4 ct.	26. Spacer.....	2 pc
12. Bracket.....	2 pc	27. Washer 6.....	14 pc
13. Bracket.....	2 pc	28. Spring washer 6.....	6 pc
14. Bracket.....	6 pc	29. Washer 8.....	20 pc
15. Bracket.....	2 pc	30. Countersunk washer 8.....	21 pc
		31. CV joint guards.....	2 pc

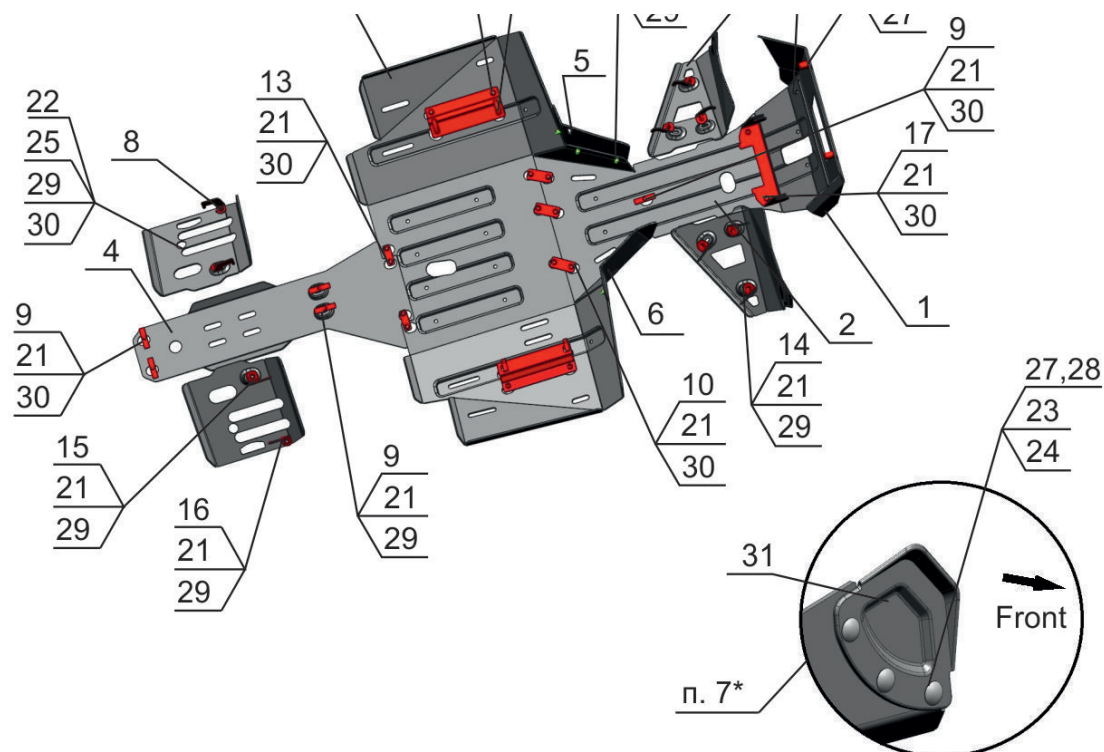

Installation Instructions

1. Take off the original plastic cover from the bumper.
2. Fix upper side of plate no.1 to original threaded apertures using screws no.22, washers no.27, spacers no.26.
3. Mount bracket no.17 on the frame by placing it toward the rear part of ATV. Place plate no.2 under plate no.1. Fix lower side of plate no.1 and together with plate no.2 to original threaded apertures using screws no.19 and washers no.27. Fix plate no.2 to brackets no.10, 17 and to insert nut M8 no.9 using bolts no.21 and washers no.30.
4. Fix plate no.4 to insert nuts M8 no.9 and to brackets no.13 using bolts no.21 and washers no.29, 30.

5. Fix bracket no.12 to insert nuts M6 no.11 using bolts no.18 and washers no.27. Fix plate no.3 to brackets no.10, 12, 13 using bolts no.21 and washers no.30.
6. Fix plates no.5, 6 to plates no.2, 3 using bolts no.21 and washers no.29.
- 7*. Fix CV joint guards no.31 to front arm guards no.7 using bolts no.23, washers no.27, 28 and nuts no.24. Fix front arm guards no.7 to brackets no.14 using bolts no.21 and washers no.29.
8. Fix rear arm guards no.8 to brackets no.15, 16 and to nuts no.25 using bolts no.21, 22 and washers no.29, 30.
9. Tighten all screws.

TOOLS REQUIRED



S-10, S-13

S-4

SCREW FORCE



M6-10 Nm



M8-30 Nm



M10-50 Nm

FRONT ARM GUARDS

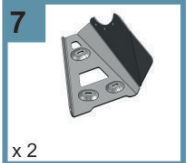

x 2



x 6



x 2

Bolt M8x25 - 6 pc
Washer 8 - 6 pc
Spring washer 6 - 6 pc
Washer 6 - 6 pc
Round-head bolt - 6 pc
Nut M6 - 6 pc

REAR ARM GUARDS

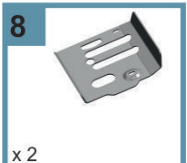

x 2



x 2

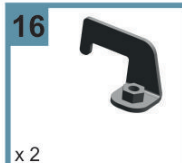

x 2

Bolt M8x25 - 4 pc
Bolt M8x50 - 2 pc
Washer 8 - 6 pc
Countersunk washer 8 - 2 pc
Nut M8 - 2 pc

BUMPER

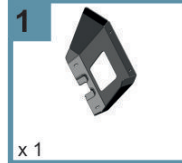

x 1

Screw M6x50 - 2 pc
Washer 6 - 2 pc
Spacer - 2 pc

FRONT REDUCER GUARD

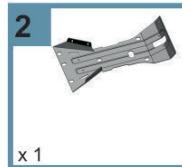

x 1

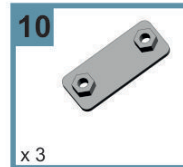

x 3

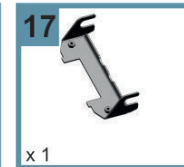

x 1

Screw M6x20 - 2 pc
Bolt M8x25 - 6 pc
Countersunk washer 8 - 6 pc
Insert nut M8 - 1 pc
Washer 6 - 2 pc

ENGINE BLOCK GUARD

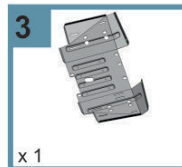

x 1

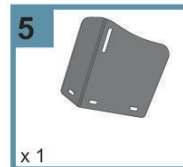

x 1

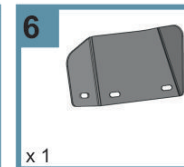

x 1

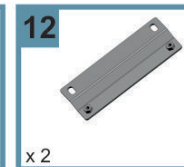

x 2

Bolt M6x20 - 4 pc
Bolt M8x25 - 15 pc
Washer 6 - 4 pc
Washer 8 - 6 pc
Countersunk washer 8 - 9 pc
Insert nut M6 - 4 pc

BACK REDUCER GUARD

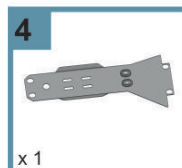

x 1

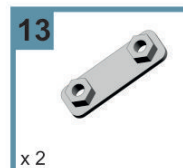

x 2

Bolt M8x25 - 6 pc
Washer 8 - 2 pc
Countersunk washer 8 - 4 pc
Insert nut M8 - 4 pc