

**EN**

**RADIATOR RELOCATION KIT WITH SNORKEL KIT  
INSTALLATION MANUAL**

**DE**

**SCHNORCHEL EINBAU- UND MONTAGEANLEITUNG**

**RU**

**ИНСТРУКЦИЯ ПО УСТАНОВКЕ ВЫНОСА РАДИАТОРА  
С КОМПЛЕКТОМ ШНОРКЕЛЕЙ**



**For: Yamaha Grizzly 700 (2016-)  
Yamaha Kodiak (2016-)**

2444.7150.1  
444.7150.1

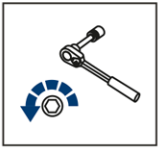

EN Regular fasteners  
DE Originale montageteile  
RU Штатный крепеж

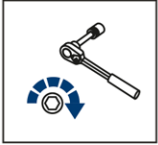

EN Regular fasteners  
DE Originale montageteile  
RU Штатный крепеж



EN Screw a several turns  
DE Für wenigen Umdrehungen befestigen  
RU Вкрутить на несколько оборотов



EN Loosen bolts  
DE Bolzen lockern  
RU Выкрутить на несколько оборотов









EN Movement Arrow  
DE Bewegungsrichtung  
RU Движение











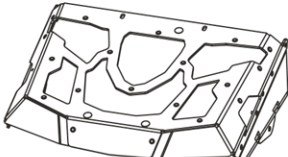
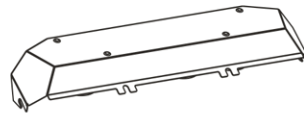
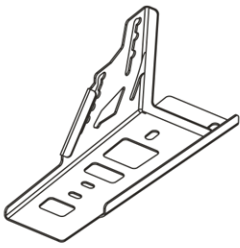
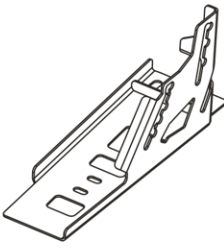
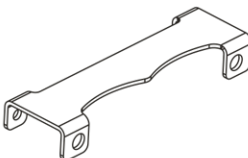
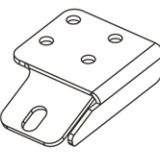
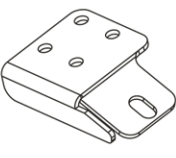

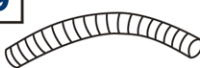

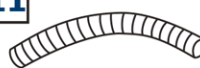





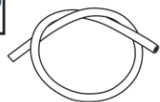





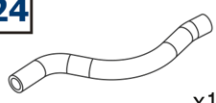
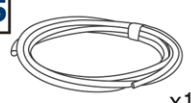

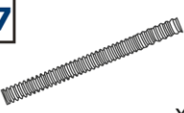

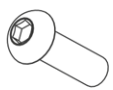

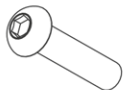

EN Location/Position Arrow  
DE Anordnung/Positionsrichtung  
RU Расположение



EN Screw Arrow  
DE Drehungsrichtung  
RU Поворот

 EN Drill DE Bohrer RU Дрель	 D=25-30 mm, D=70-76 mm	 EN Ratchet DE Ratsche RU Трещётка	 S - 10; S - 13; S - 15	 EN Sealant DE Dichtmasse RU Герметик	 EN Office Knife DE Büromesser RU Канцелярский нож
---	---	---	--	--	---

<b>1</b>  x1	<b>2</b>  x1	<b>3</b>  x1	<b>4</b>  x1		
<b>5</b>  x1	<b>6</b>  x1	<b>7</b>  x1	<b>8</b>  x2		
<b>9</b>  L=1,1m x1	<b>10</b>  L=1,2m x1	<b>11</b>  L=1,3m x1	<b>12</b>  H=16 x2	<b>13</b>  M6 x2	<b>14</b>  M8 x4
<b>15</b>  Ø20 x2	<b>16</b>  Ø20 x1	<b>17</b>  x1	<b>18</b>  10-16 x2	<b>19</b>  20-32 x6	<b>20</b>  60-80 x7
<b>21</b>  70-90 x3	<b>22</b>  x10	<b>23</b>  x1	<b>24</b>  x1	<b>25</b>  x1	<b>26</b>  x1
<b>27</b>  x1	<b>28</b>  60-80 x2	<b>29</b>  M6x20 x8	<b>30</b>  M8x20 x6	<b>31</b>  M8x40 x2	<b>32</b>  Ø63 x1
<b>33</b>  M6 x4	<b>34</b>  M8 x2	<b>35</b>  Ø60-80 x1	<b>36</b>  Ø6 x4	<b>37</b>  Ø6 x8	<b>38</b>  Ø8 x10
<b>39</b>  Ø6 x4	<b>40</b>  Ø8 x4				

**EN** Attention! All flexible hose couplings are designed with a sealant.

**DE** Achtung! Alle flexiblen Schlauchkupplungen werden mit einem Dichtmittel ausgeführt.

**RU** Внимание! Все соединения гибких рукавов выполнять с использованием герметика

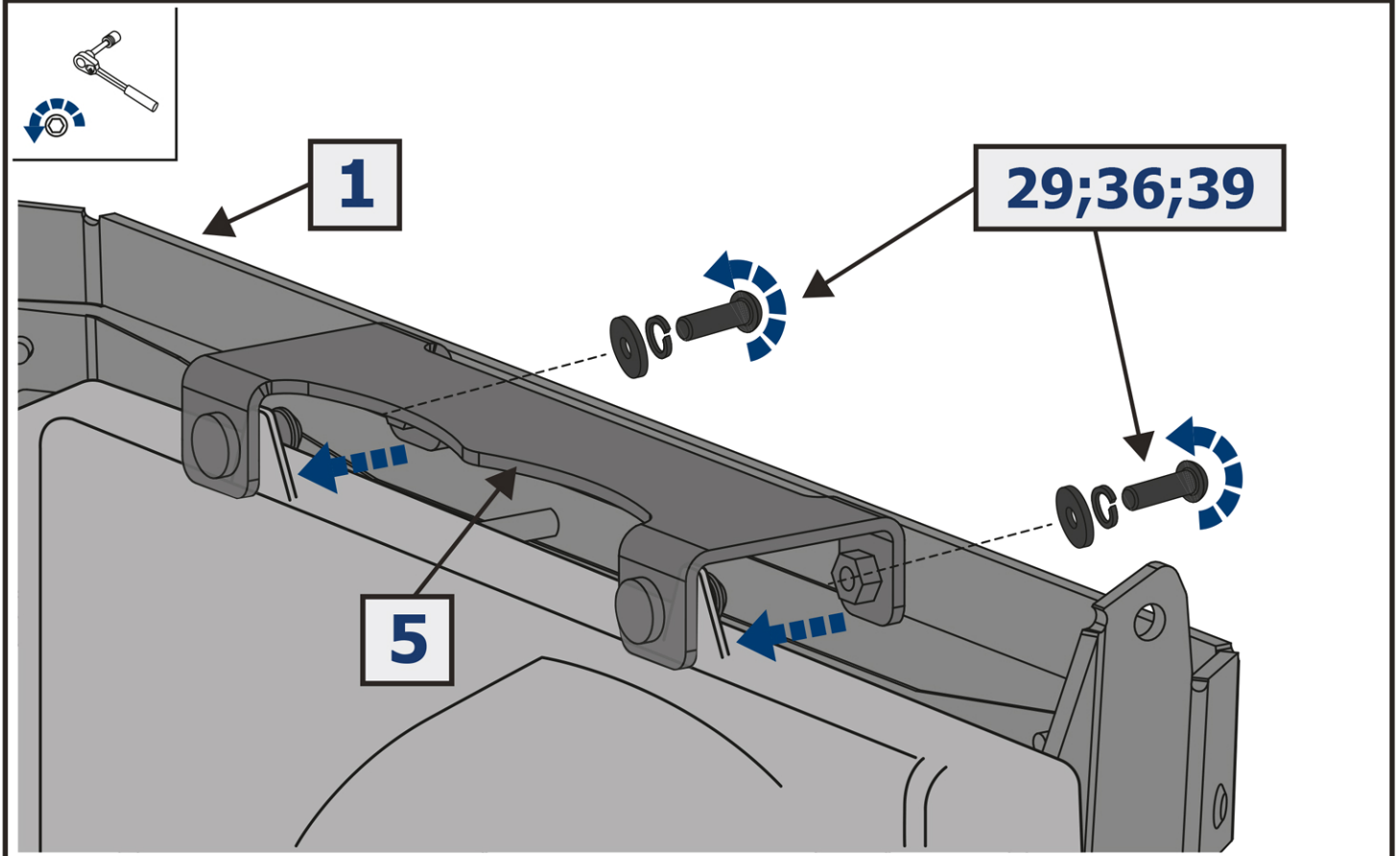
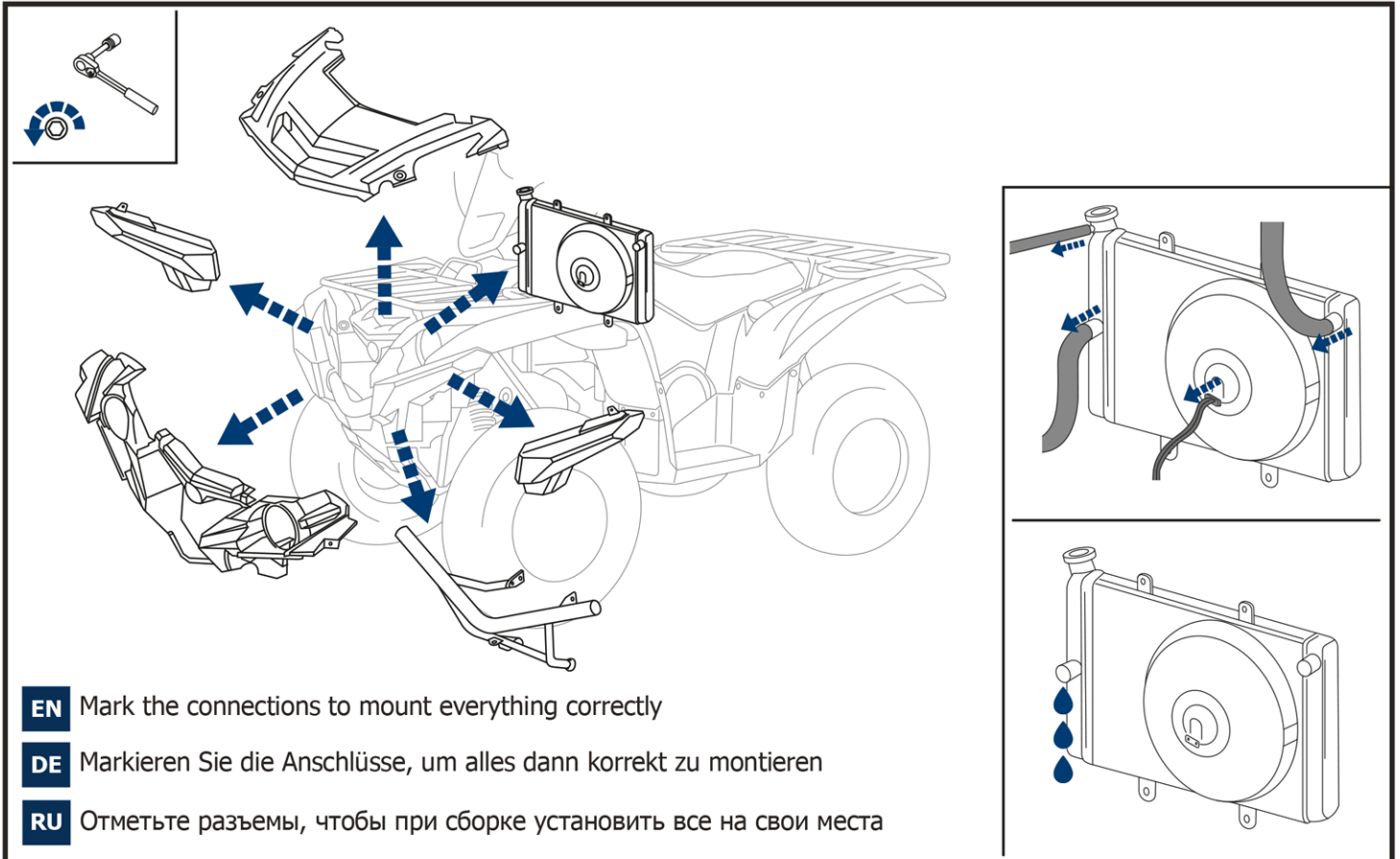

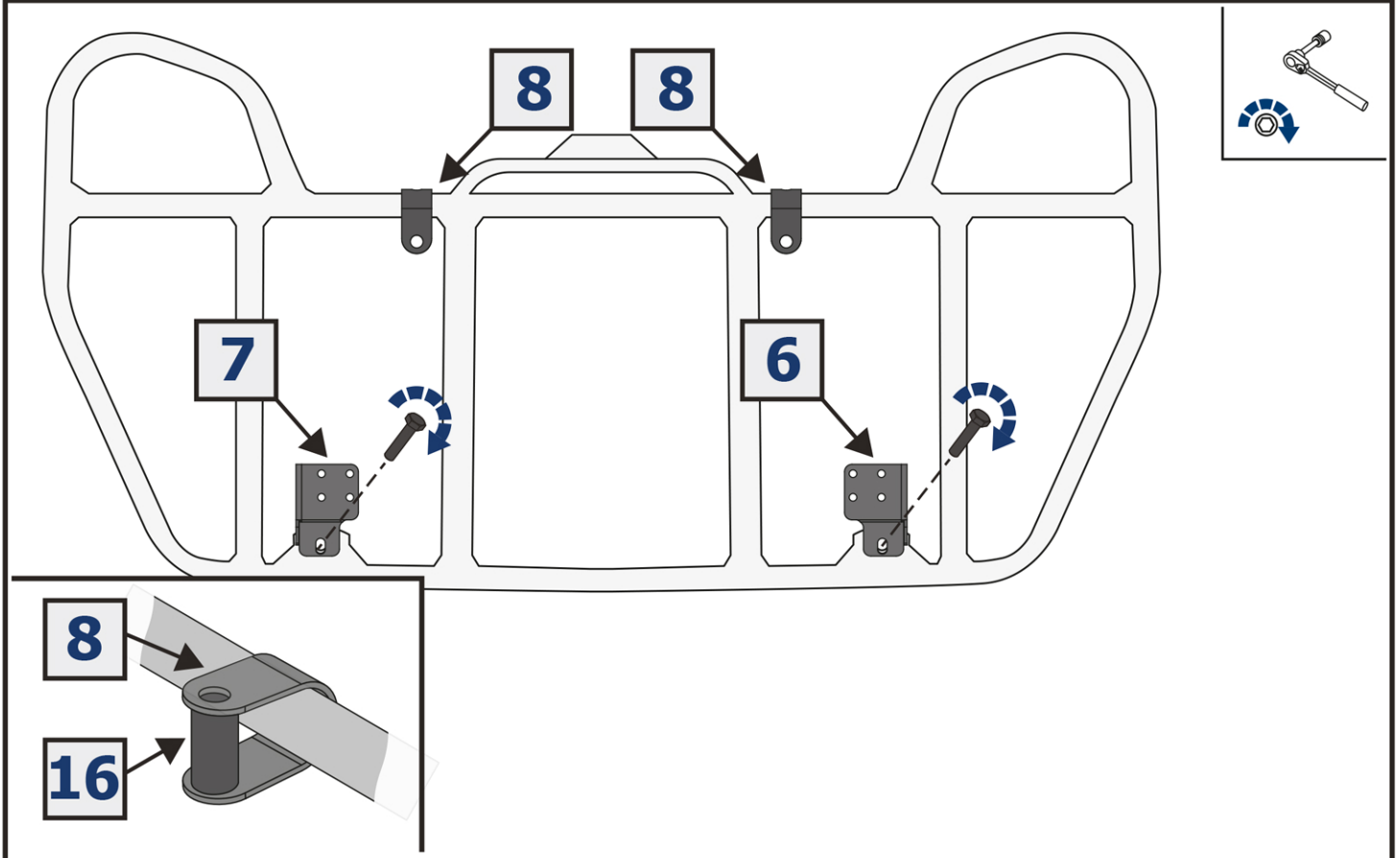
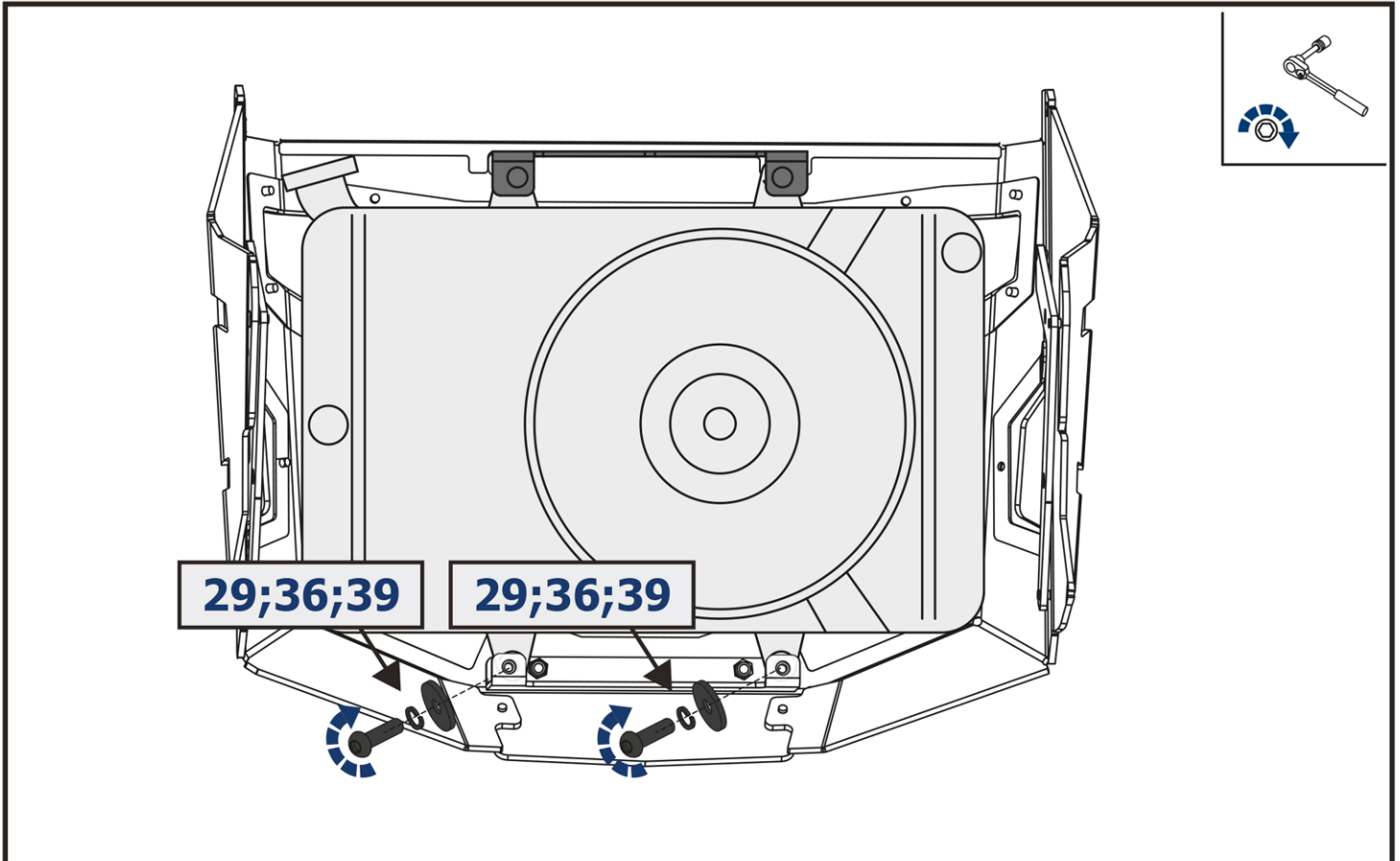

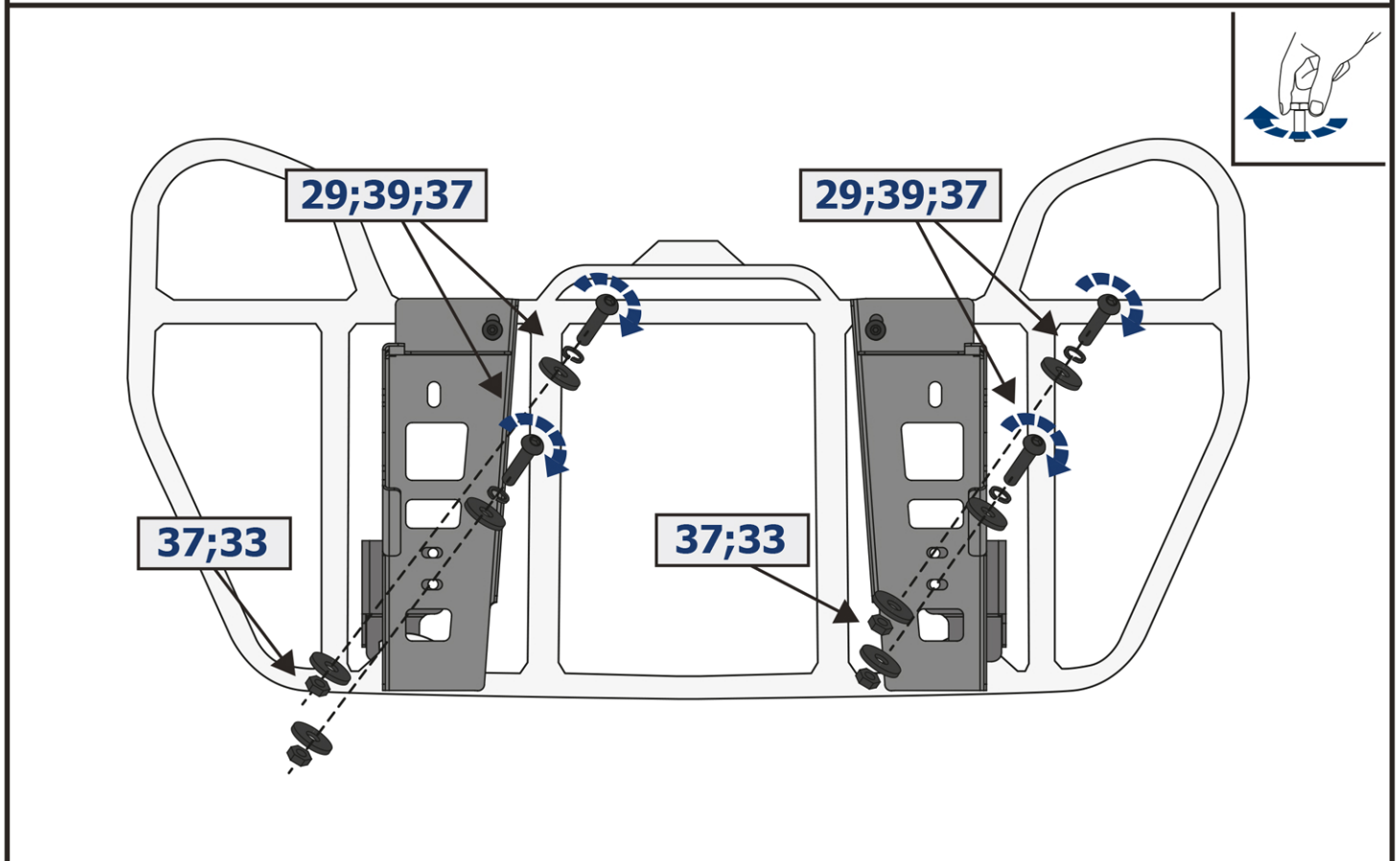
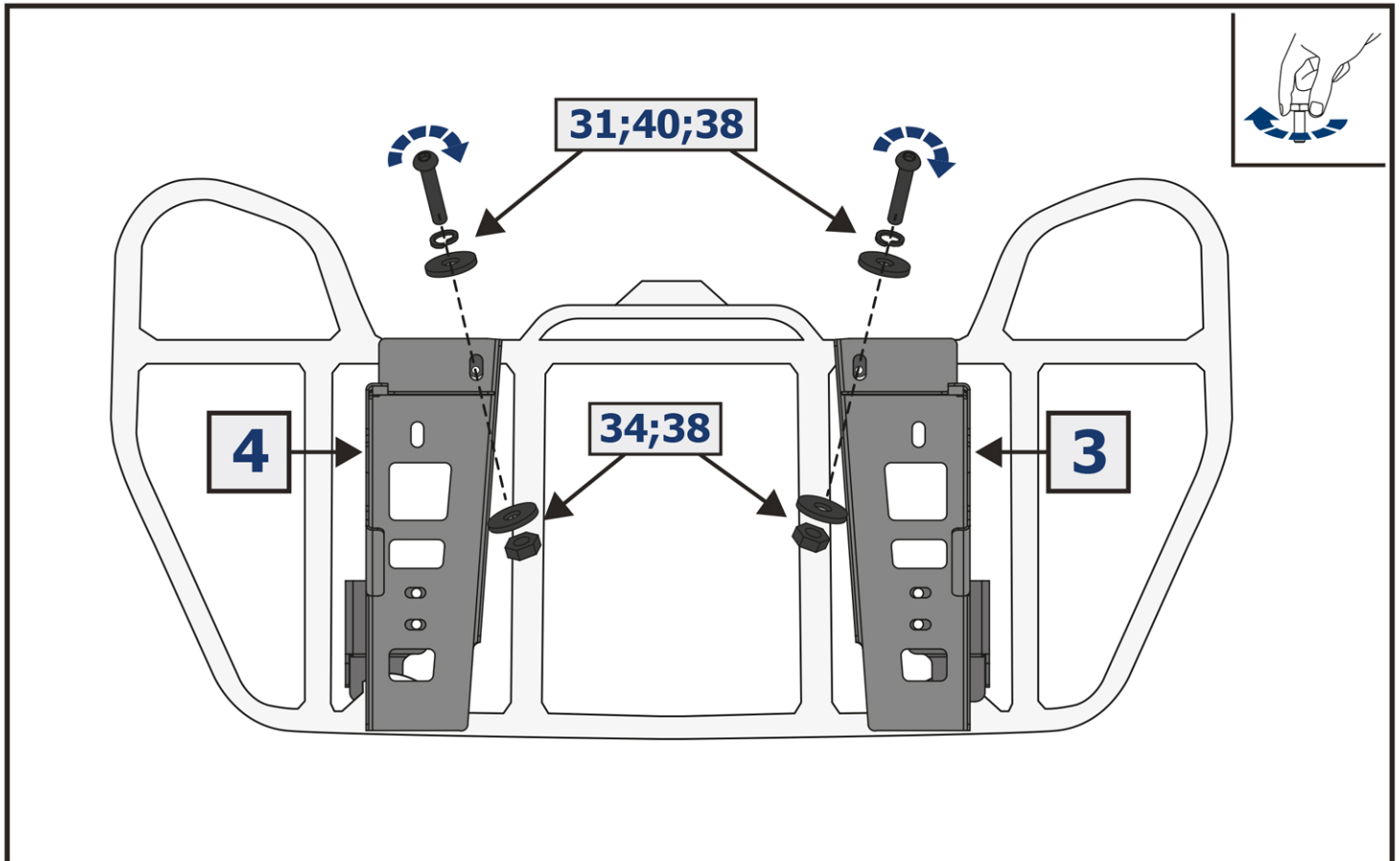

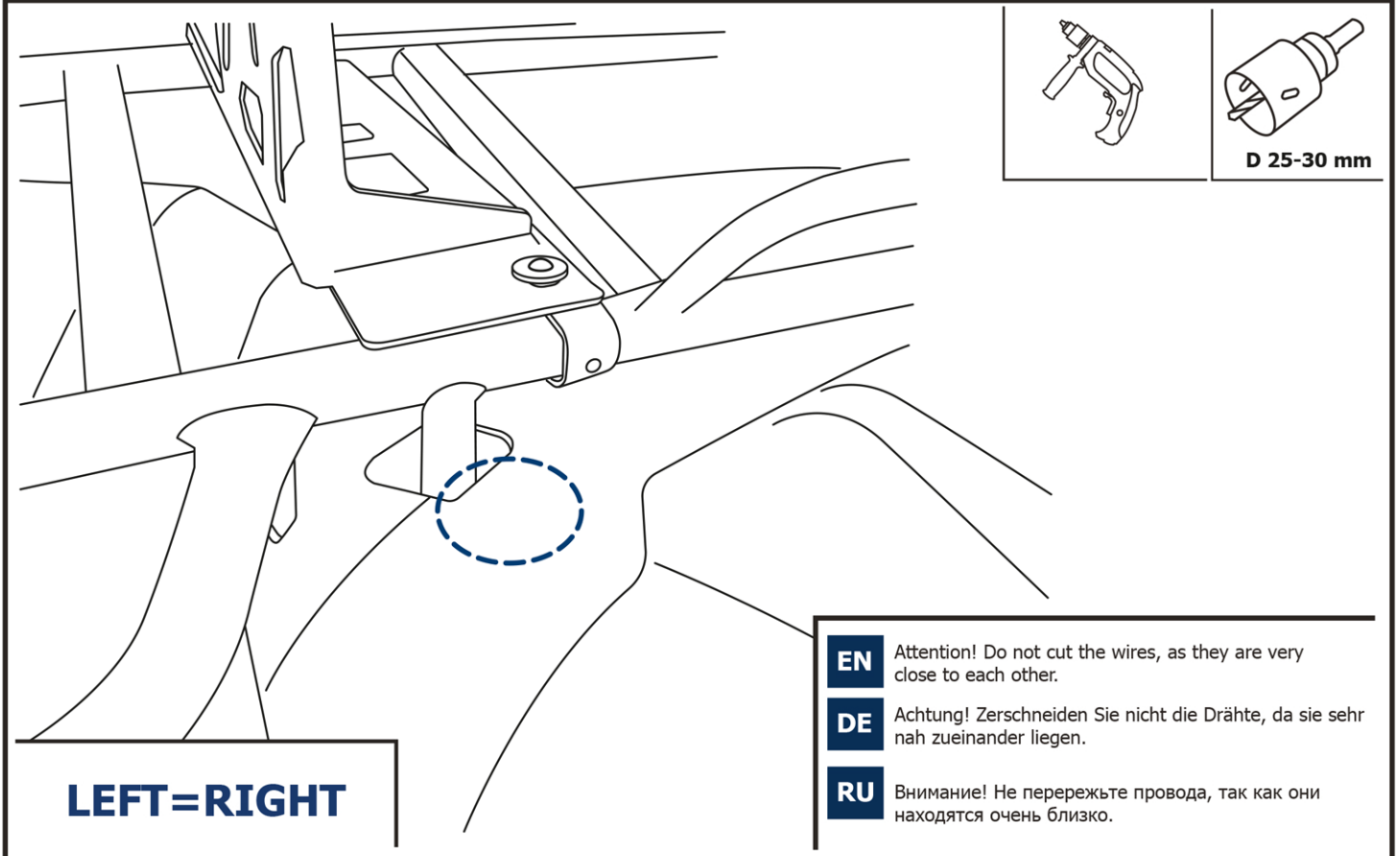
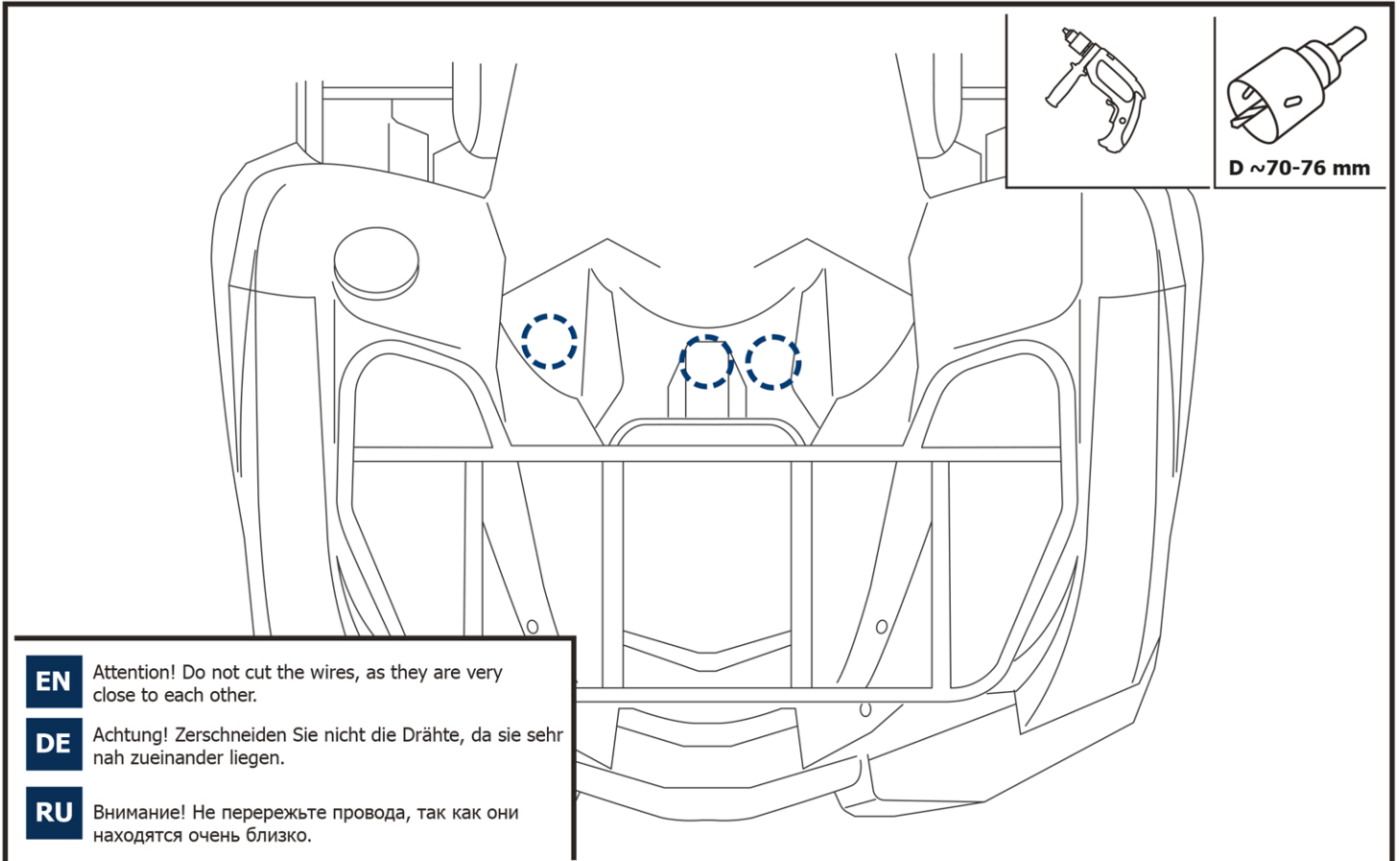

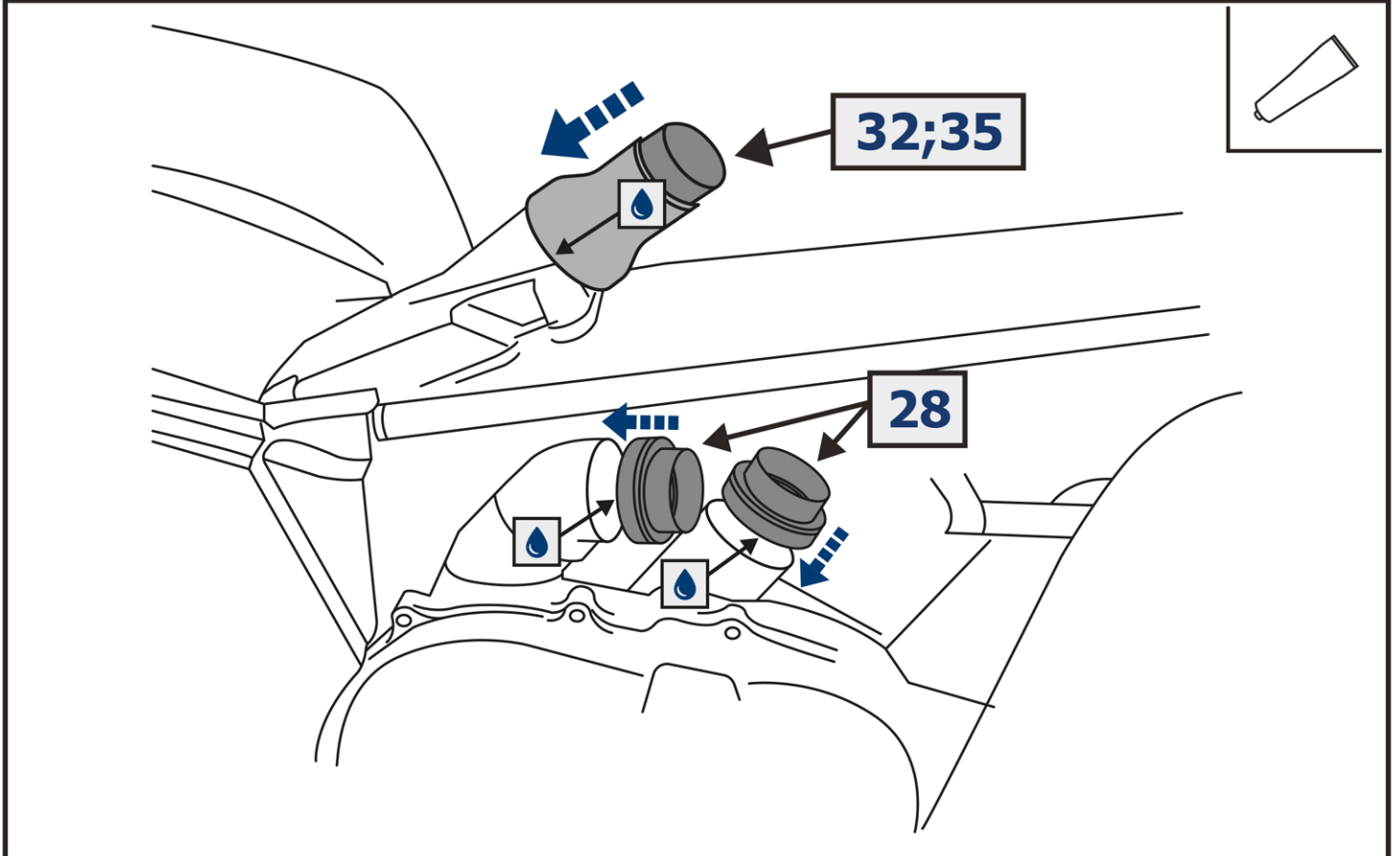
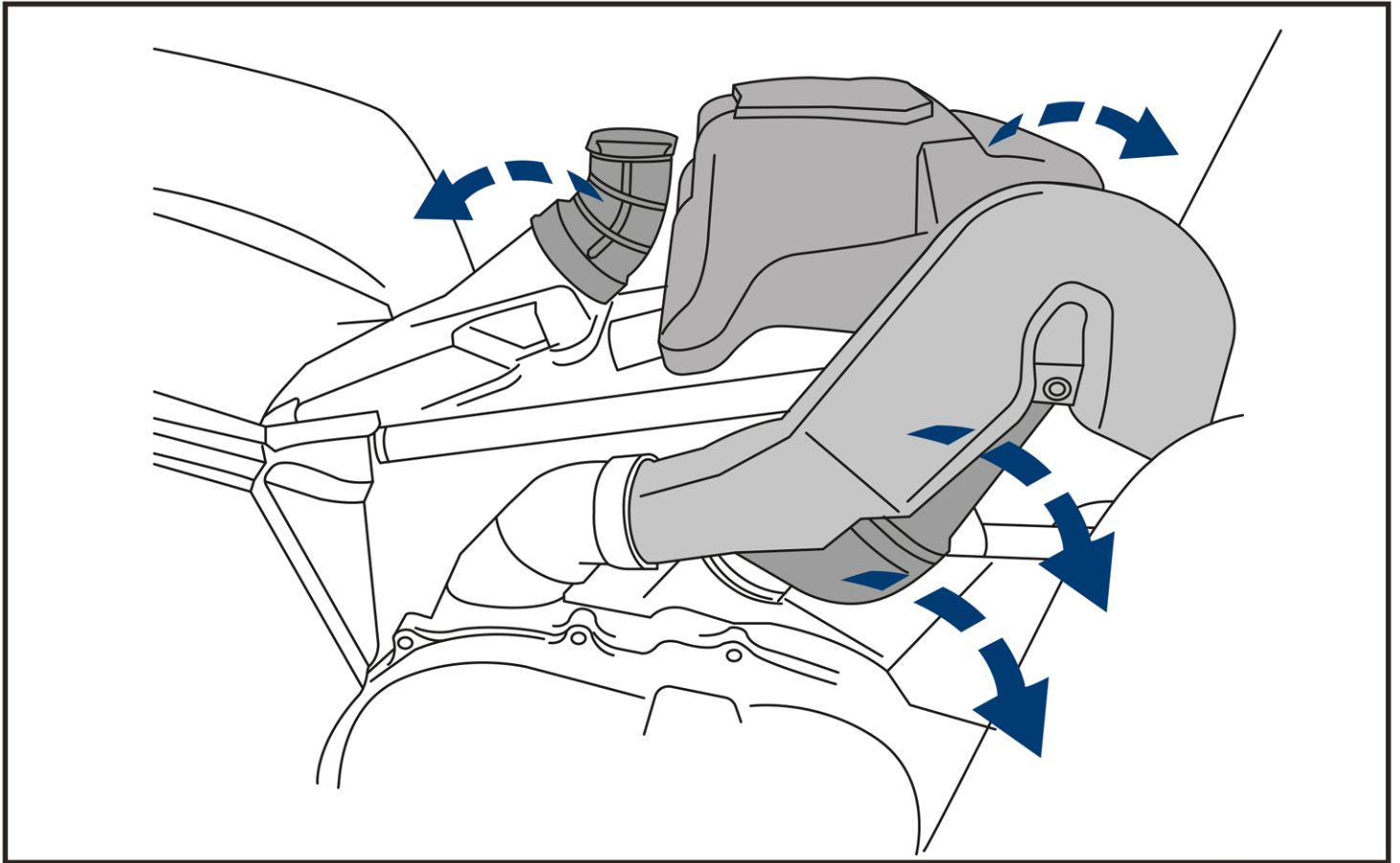



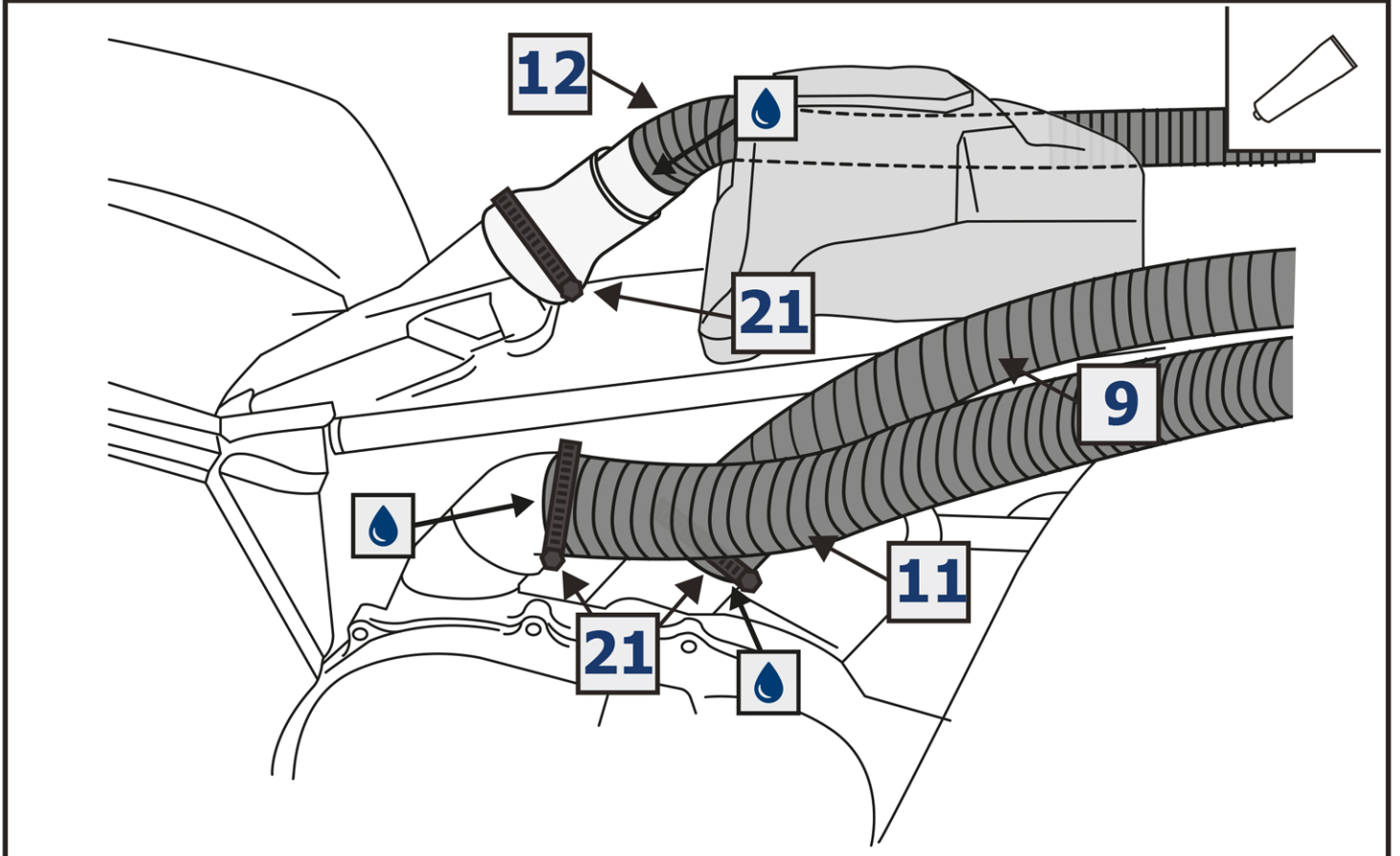
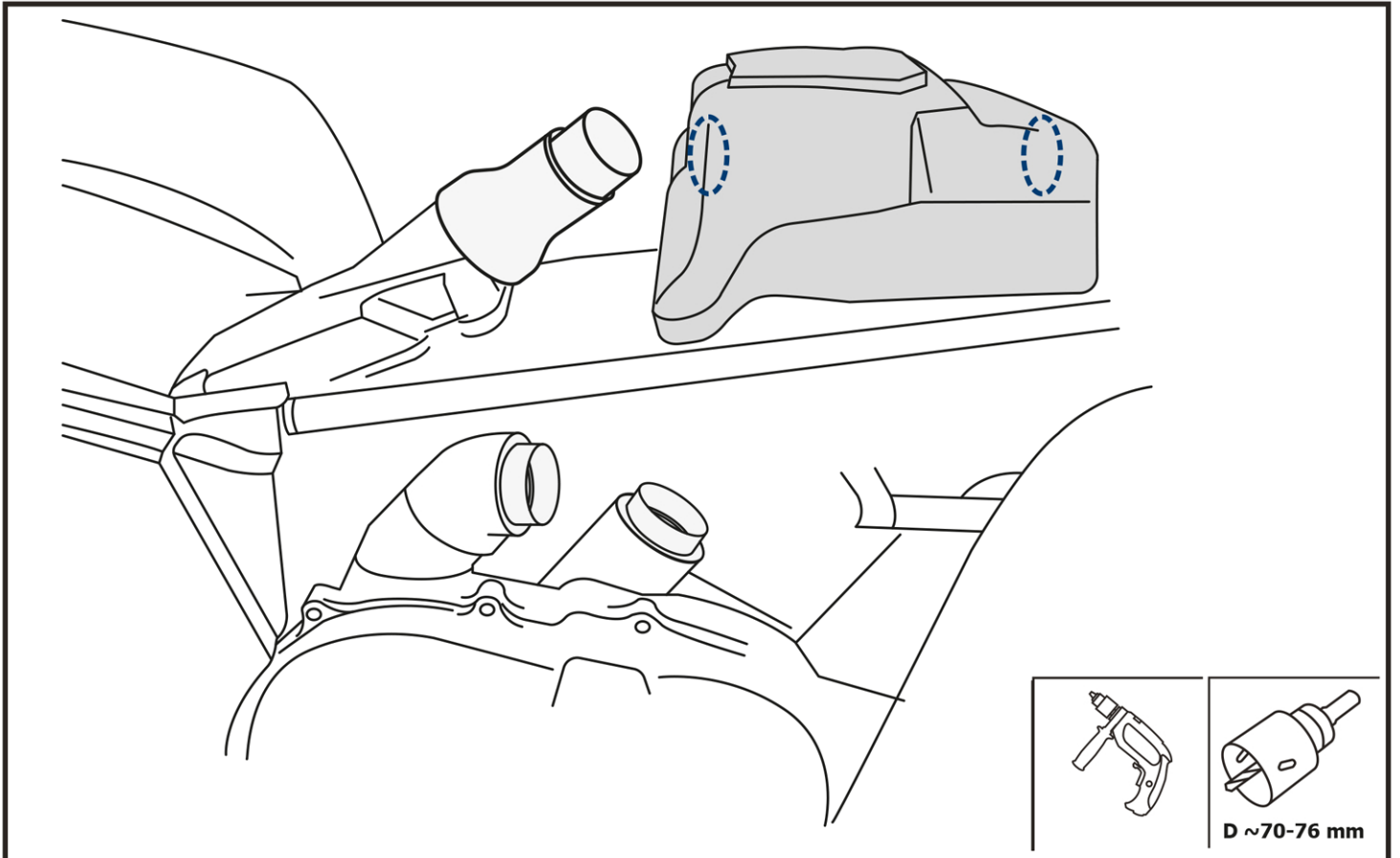

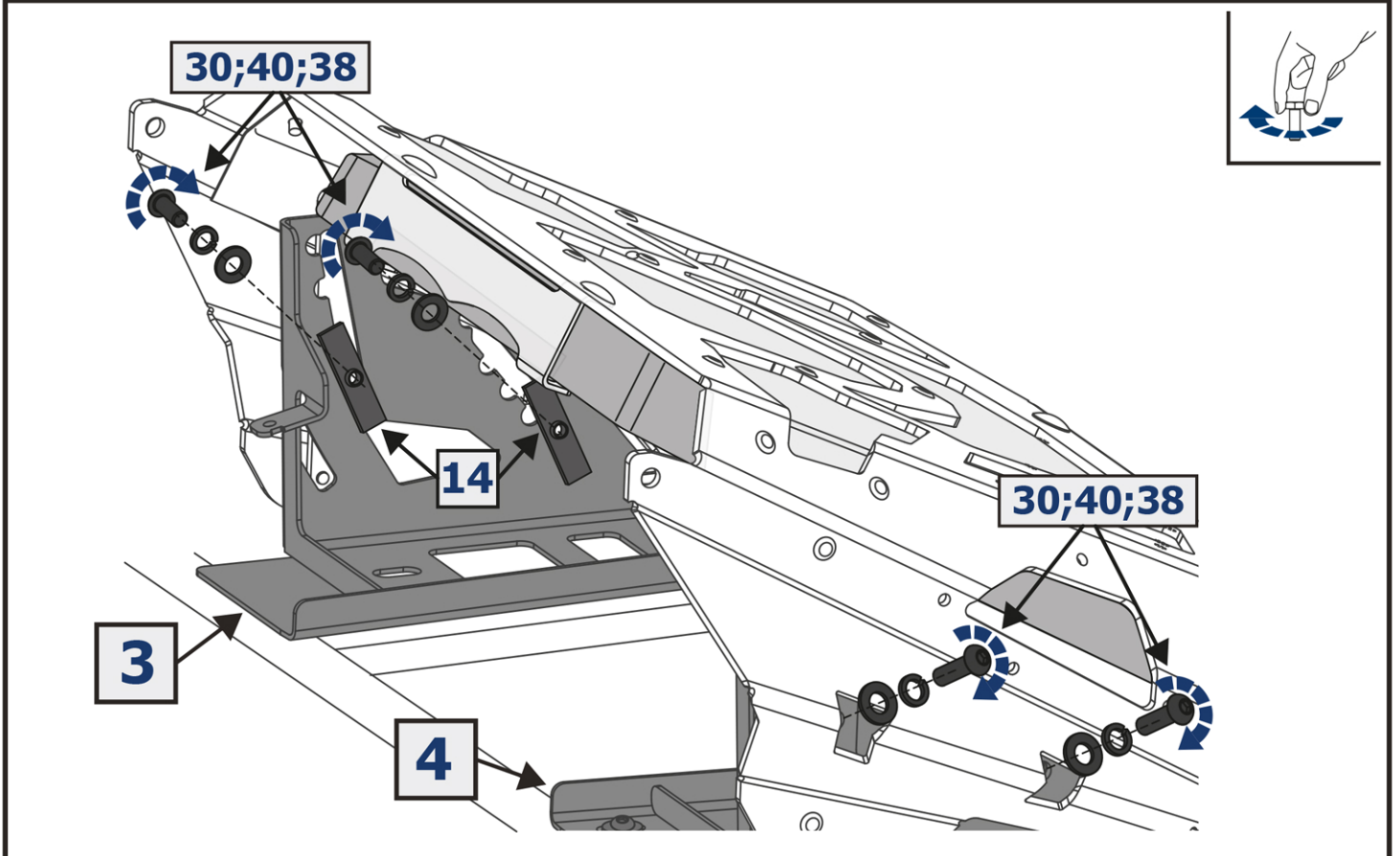
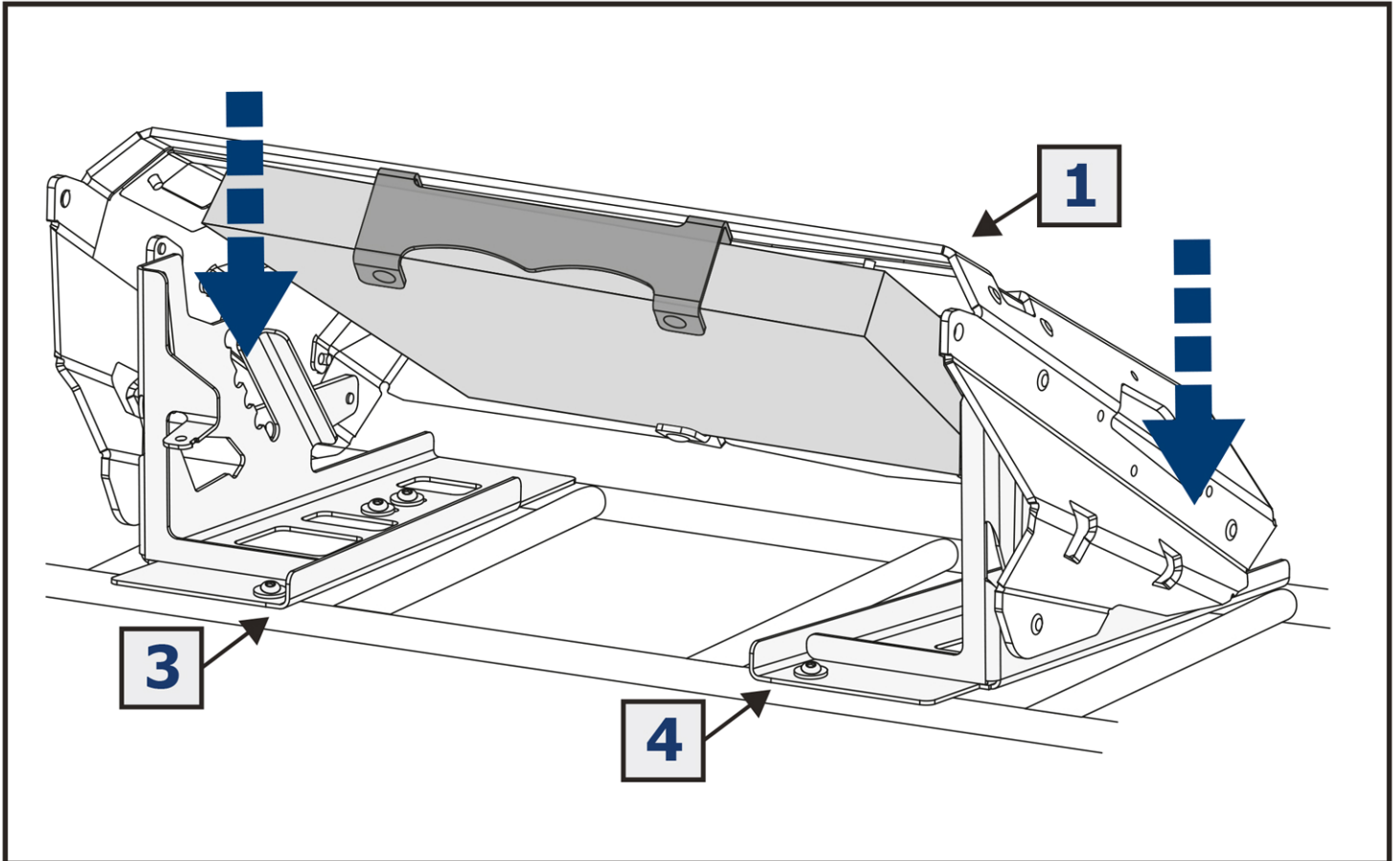

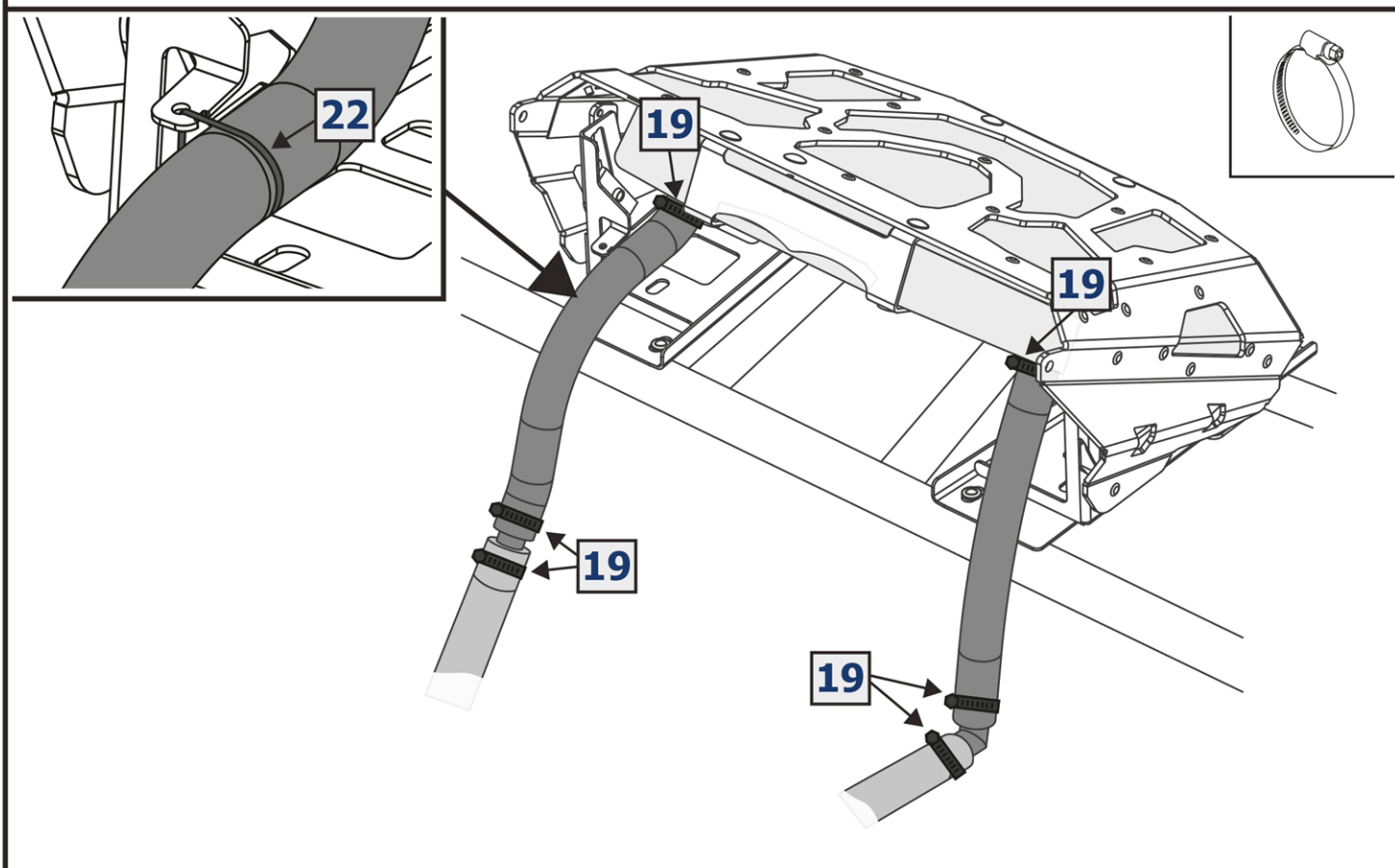
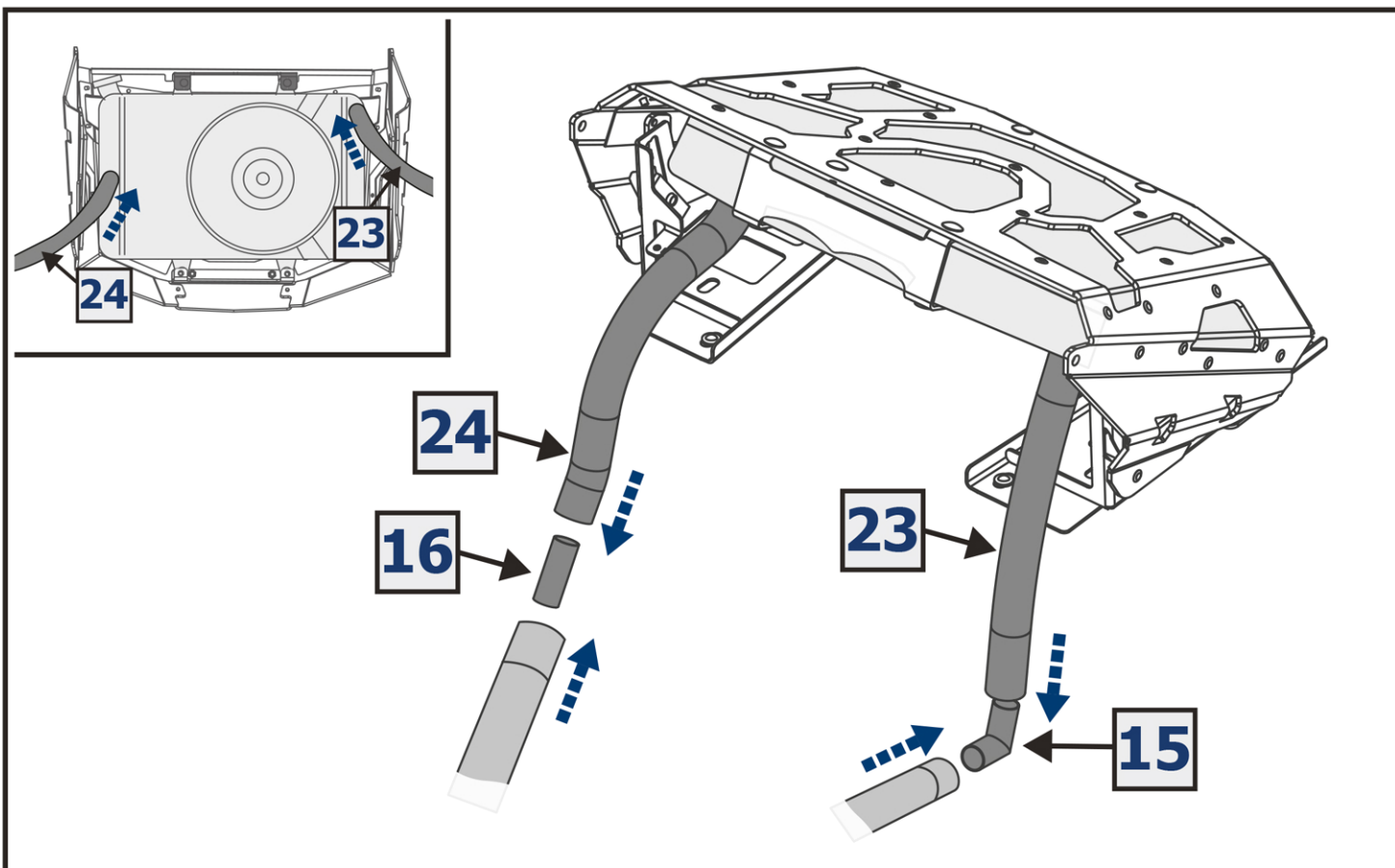

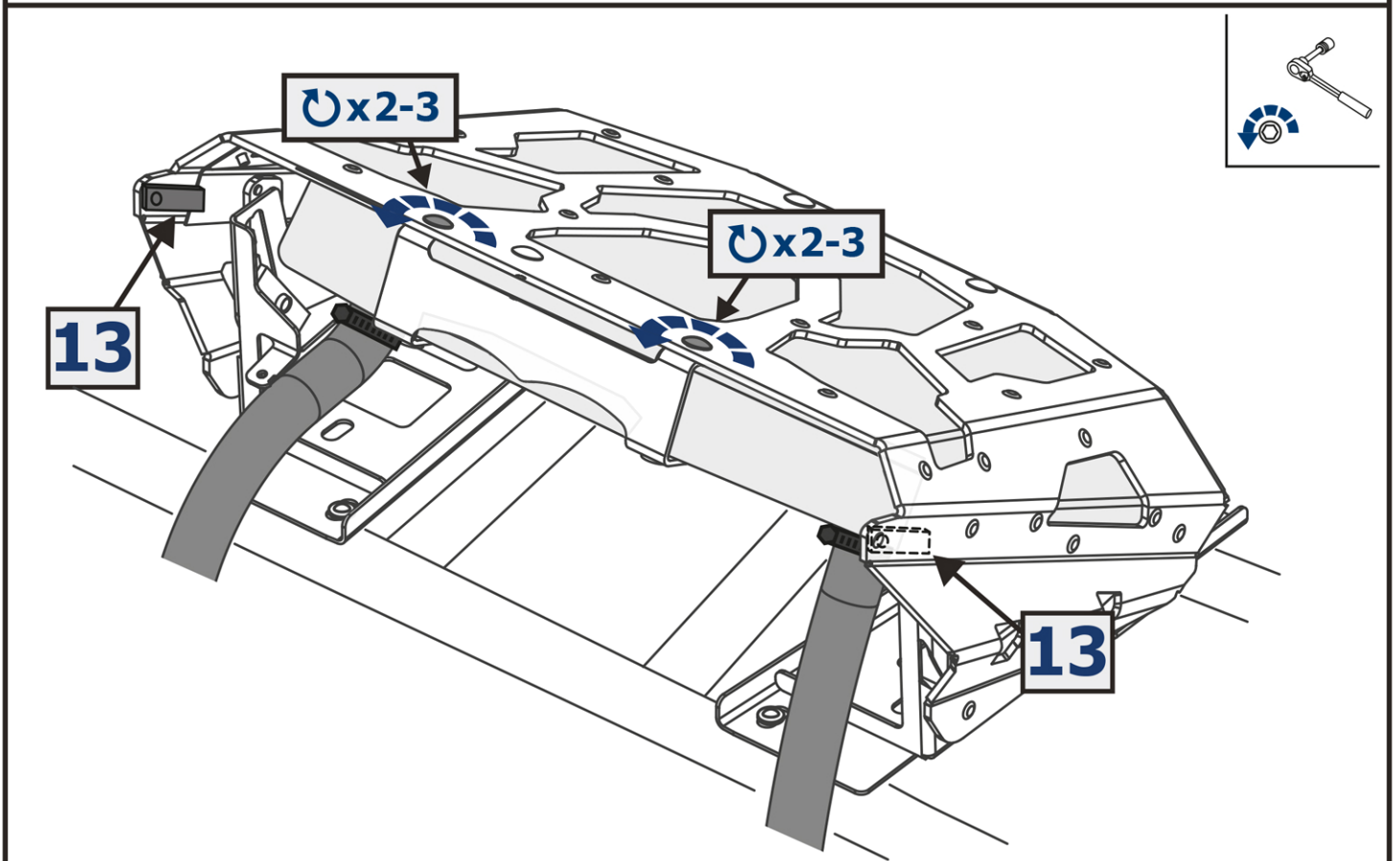
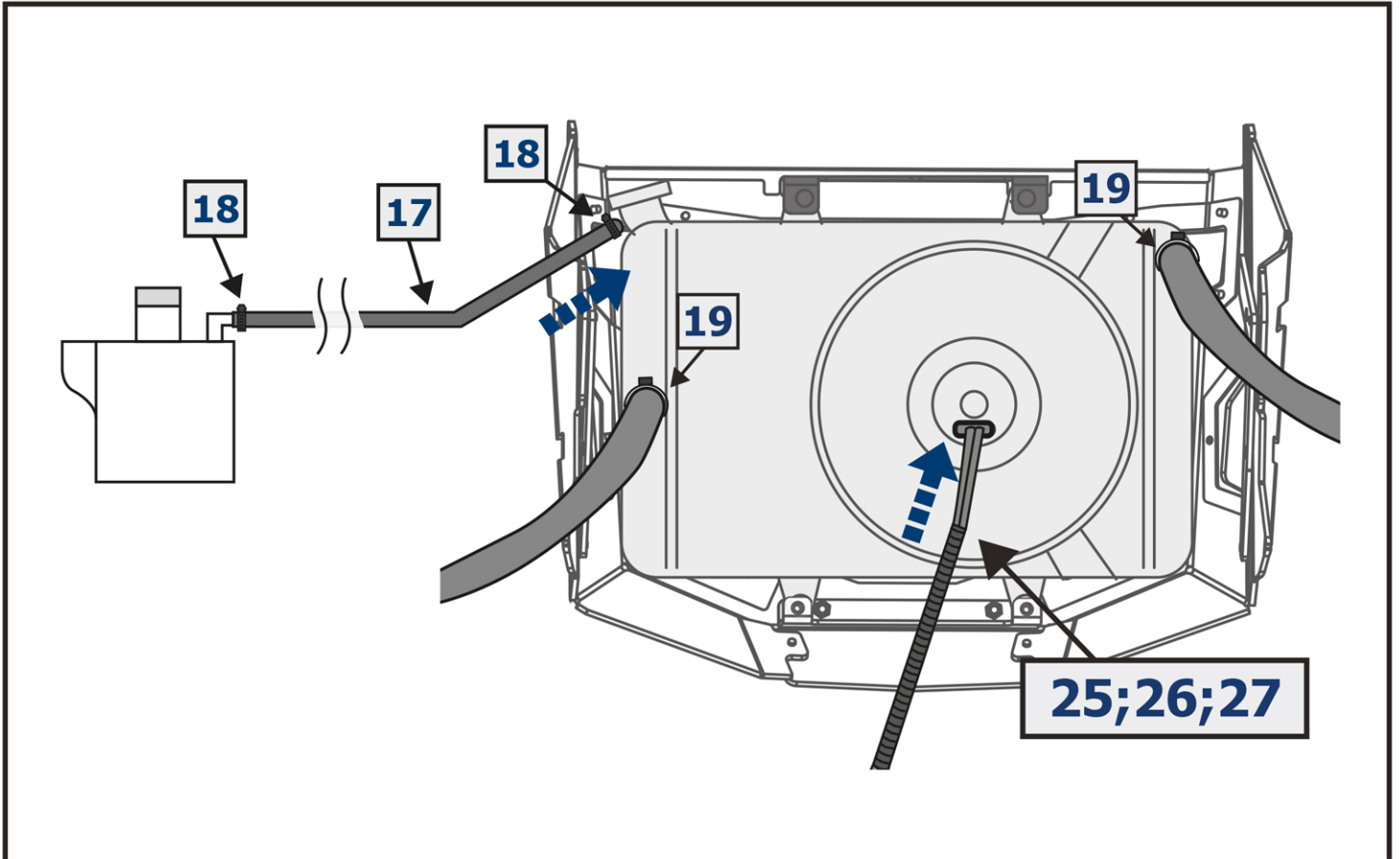

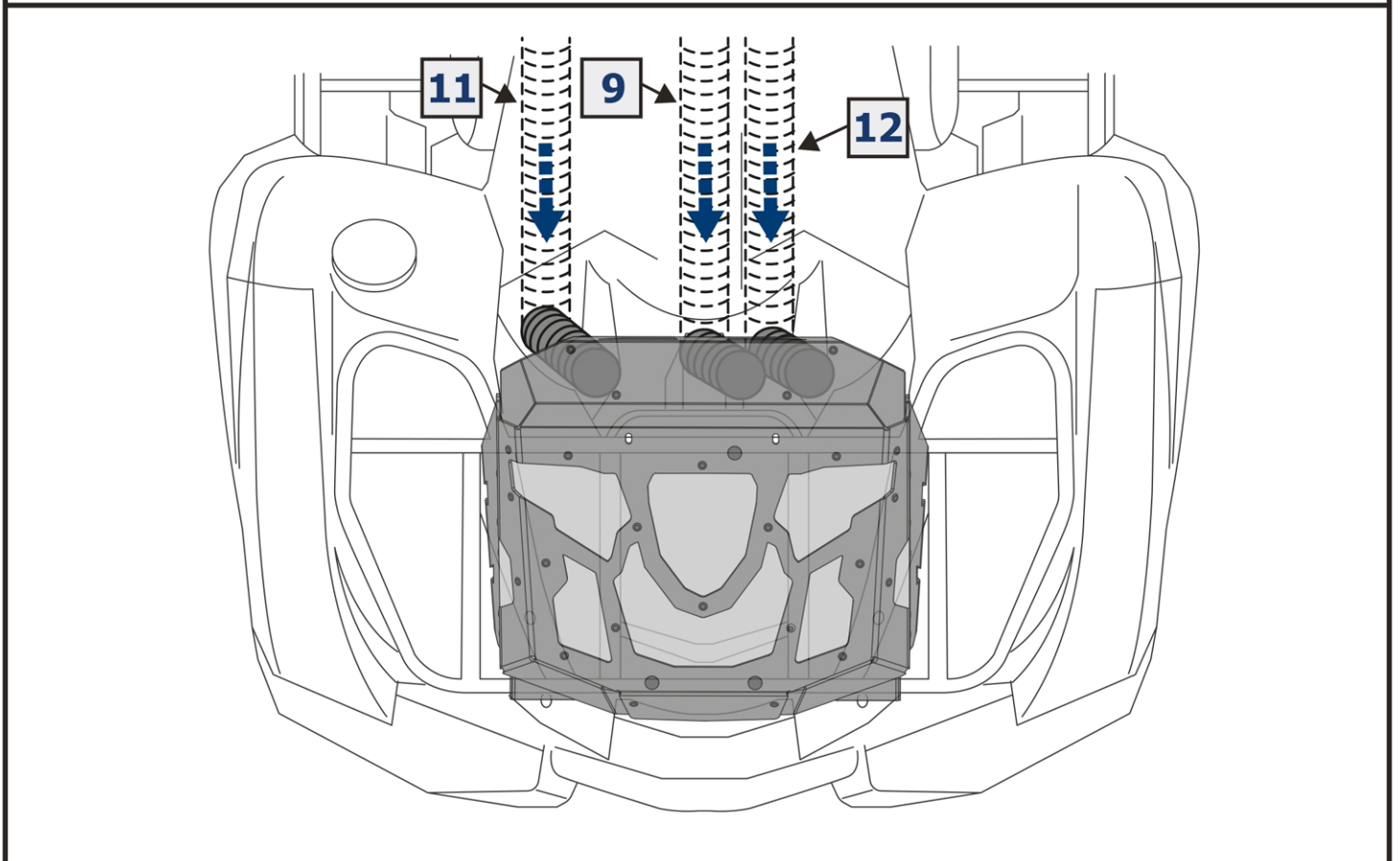
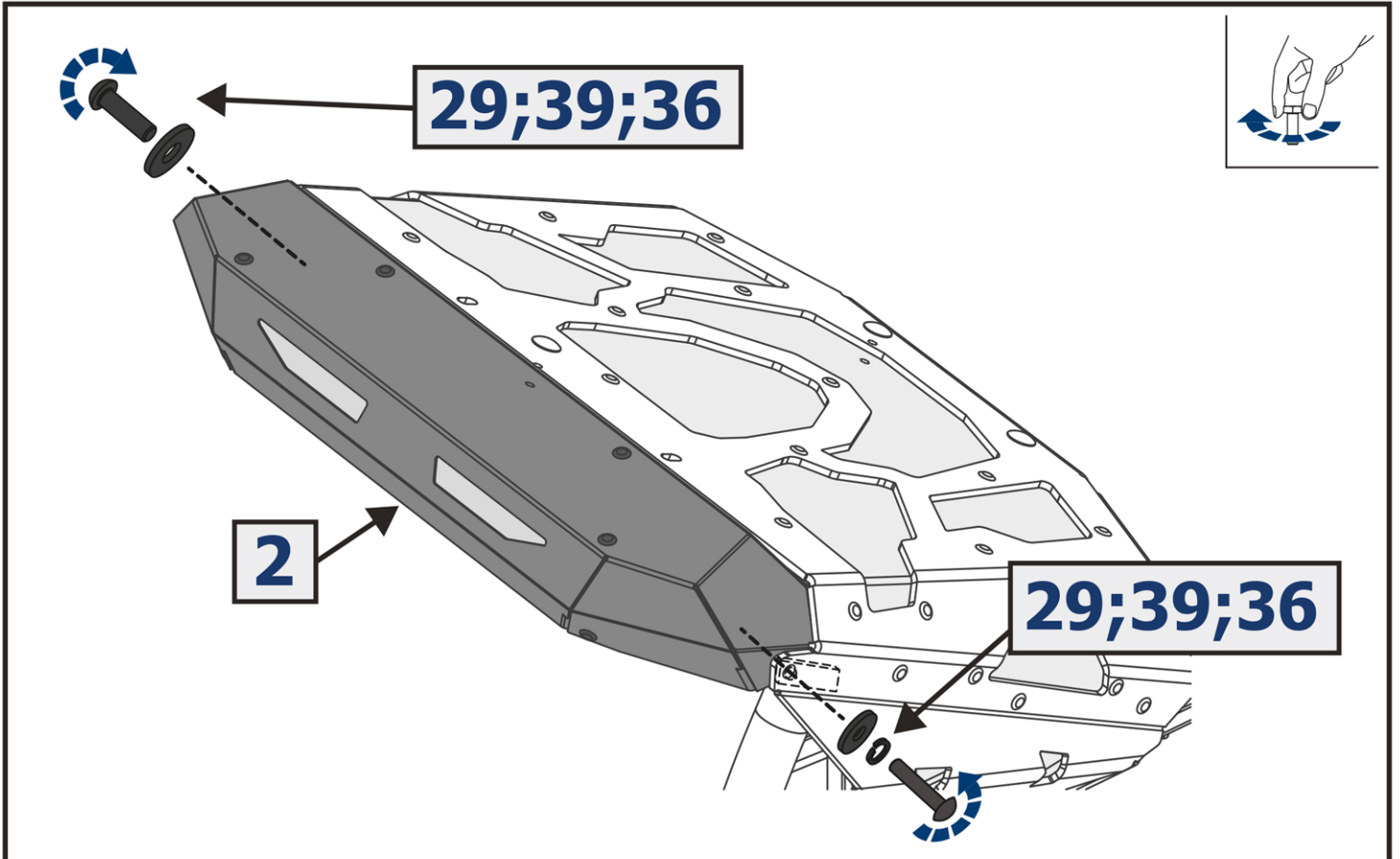

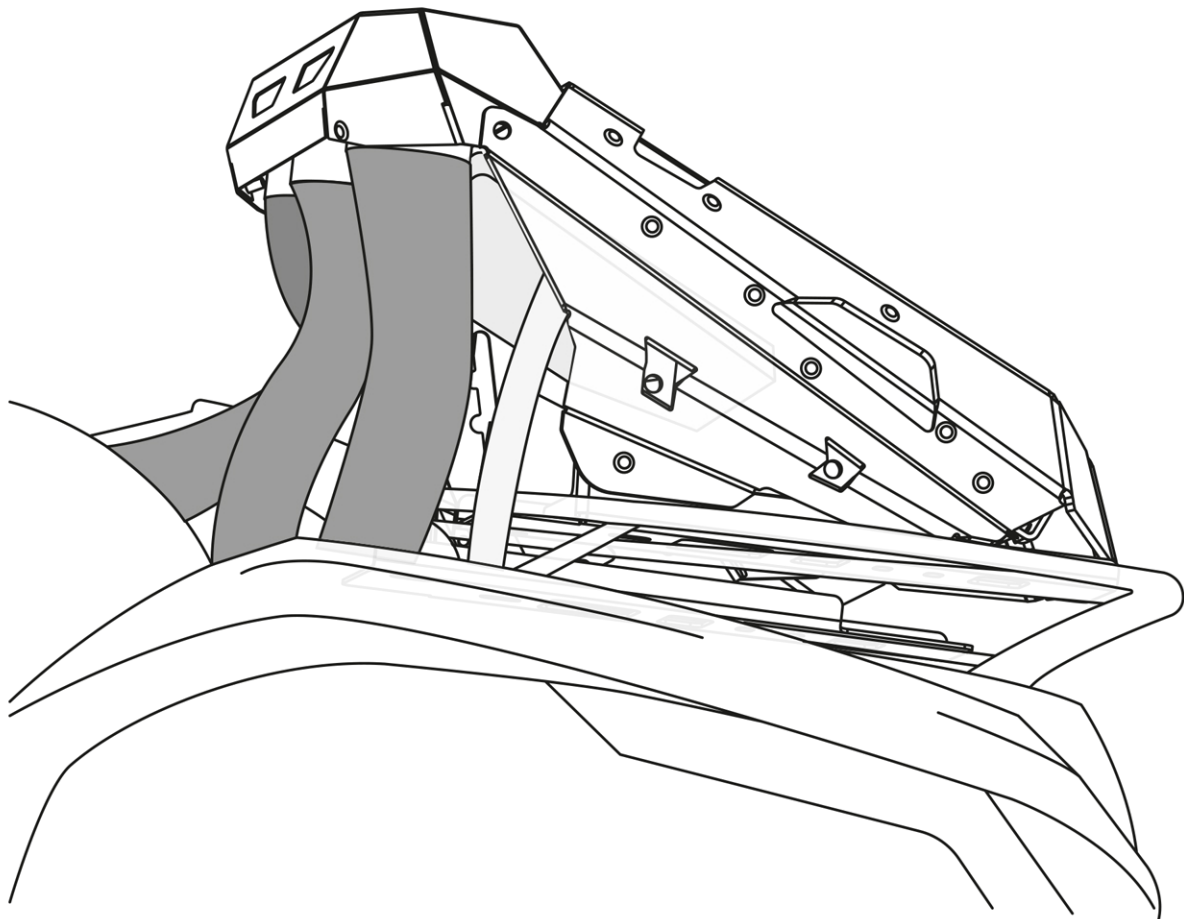

**EN**

Connect hose pipes to the rear cover using collars 60-80 (pos. **20**) and cut the excessive part. Make sure there is no rubbing sharp edges against the hose pipes. Where required, secure the hose pipes using hose ties (pos. **22**). Install all plastic parts into position in reverse order.

**DE**

Verbinden Sie die Schläuche mit den Klemmen 60-80 an den hinteren Deckel (Pos. **20**)  
Schneiden Sie den Überschuss ab. Stellen Sie sicher, daß die Schläuche keine scharfen Kanten berühren. Befestigen Sie gegebenenfalls die Schläuche mit den Schellen (Pos. **22**)  
Montieren Sie nun alle Kunststoffteile in umgekehrter Reihenfolge.

**RU**

Подключите рукава к задней крышке с помощью хомутов 60-80 (поз. **20**) отрежьте лишнее. Убедитесь в отсутствии трущихся острых граней об рукава. При необходимости закрепите рукава хомутами-стяжками (поз. **22**)  
Установить все пластиковые детали на места в обратном порядке.

**EN** Attach temperature sensor connectors, fan connector and fan breather connector. For complete adjustment of the overhang by inclination angle, extend wires when necessary pos. **25, 26, 27**.

**DE** Schließen Sie die Steckverbindungen des Temperatursensors, den Stecker des Ventilators und des Entlüfters an. Für die vollständige Einstellung der Austragung je nach dem Anstellungswinkel verlängern Sie soweit erforderlich Kabel an der Positionen **25, 26, 27**.

**RU** Подсоединить разъемы датчика температуры, разъем вентилятора и сапуна вентилятора. Для полной регулировки выноса по углу наклона при необходимости удлинить провода поз. **25, 26, 27**.

**EN** Provide strong fastening of all branch pipes by zap straps pos. **22** to the frame and between each other in a way that they do not touch sharp edges under the luggage rack platform. As branch pipes are movable when being higher than the luggage rack platform due to adjustment of the relocation kit by inclination angle, please prevent touching of branch pipes and the hood and the luggage rack platform in order not to allow their abrasion.

**DE** Befestigen Sie alle Stützen mit Hilfe der Spannschellen (Position **22**) sicher zum Gestell und zueinander so, dass sie die scharfen Ränder unterhalb dem Gepäckraum nicht berühren. Da die Stützen über dem Gepäckraum wegen der Einstellung der Austragung je nach dem Anstellungswinkel beweglich sind, müssen sie mit der Haube und dem Gepäckraum nicht berühren, um deren Scheuern zu vermeiden.

**RU** Все патрубки надежно закрепить хомутами-стяжками поз. **22** к раме и между собой так, чтобы они не касались острых граней ниже багажной площадки. Так как выше багажной площадки патрубки подвижны из-за регулировки выноса по углу наклона, необходимо исключить касание патрубков с капотом и багажной площадки, во избежание их перетирания.

**EN** Install the radiator relocation kit in the highest lifted position, add antifreeze liquid and bleed the system.

**DE** Stellen Sie die Austragung des Kühlers in die höchstzulässige angehobene Position ein, gießen Sie Frostschutzmittel ein und entlüften Sie das System.

**RU** Установить вынос радиатора в максимально поднятое положение, залить антифриз, прокачать систему.